

# SM-RBX-PRO-8-BLK Dual-Layer Enclosure

## Assembly Instructions

### Contents

- 1 × Enclosure
- 1 × Central Support Plate
- 1 × Cover Plate
- 1 × Dust Cover
- 1 × Trim Bezel
- 6 × Silicone Grommets
- 1 × Hardware Pack

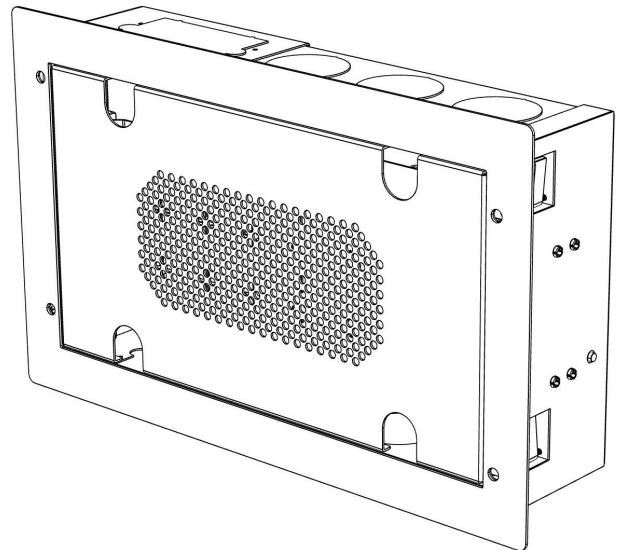

### Installation Needs

- #1 Phillips screwdriver
- Drywall saw
- Tape measure
- Level
- ¼" flathead screwdriver
- Electric drill and ¼" bit

### Optional Accessories and Hardware

- Drywall screws
- Electrical box and low voltage ring for adding terminations to cutouts
- Compact WattBox (sold separately)

**Danger:** This equipment must be installed and assembled by qualified service personnel in accordance with local building codes. Contact a suitable contractor if necessary.

**Caution:** Before beginning, carefully plan locations, accounting for electrical, ductwork, plumbing or other obstacles that may interfere with installation of the box, equipment, or wiring.

**Note:** Use only standard-size cover plates on boxes and rings installed in the Strong VersaBox. Mid- and jumbo-size plates will not fit.

## Installation

Remove the cover plate by pulling the finger openings on one side of the cover to pop it loose.

Open any knockouts in the VersaBox Pro that will be used for wiring.

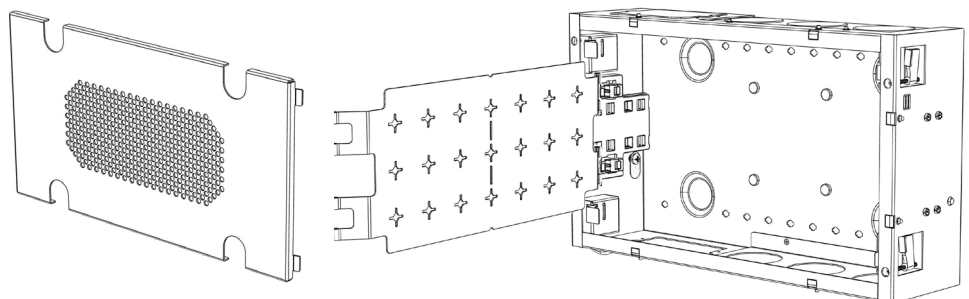

## Drywall Mounting with Dogs

Locate two studs. Use the cutout template to mark the wall, centered between the studs. Use a level to align it correctly.

Cut the opening using a drywall saw. Test fit the box, and clean up the opening as needed.

Thread the wiring and cabling through the knockouts, then insert the enclosure.

Use a #1 Phillips screwdriver to tighten the dog screws as illustrated. All four dogs must be engaged with the drywall to mount the box securely.

Secure the trim bezel with 8 screws on the inside of the enclosure.

**Pro Tip:** If any of the four dogs do not extend correctly due to stud clearance, insert a screw through the side of the box into the adjacent stud. Refer to Stud Mounting with Lag Bolts, below.

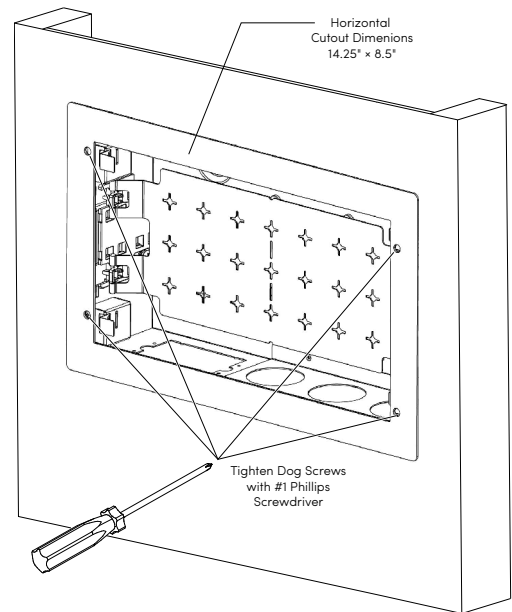

## Stud Mounting with Lag Bolts

**Pro Tip:** For new construction work, account for the drywall thickness when installing. If the studs are wider than 16" apart, or if you are mounting vertically, install using dogs once the drywall is finished. See the Drywall Mounting with Dogs section above for details.

*If this is a retrofit job, locate two studs. Use the cutout template to mark the wall, centered between the studs. Use a level to align it correctly. Cut the opening using a drywall saw. Test fit the box, and clean up the opening as needed.*

Remove the center support plate from the VersaBox.

Remove the platform standoffs by inserting a ¼" flathead screwdriver into the gap between the standoff and case. Twist the screwdriver and pry outward to remove each standoff. ❶

Thread the wiring and cabling through the knockouts. Insert the enclosure.

Remove the plugs from the mounting holes you wish to use (right). Drill ¼" pilot holes and drive the lag bolts to secure the VersaBox. ❷

If desired, you can rotate the standoff 180° to change the clearance of the central support plate. ❸

Press the standoff back in until it snaps into place. ❹

*If this is new construction, insert the dust cover to protect the inside of the VersaBox Pro from the drywall install. Once drywall is installed, remove the dust cover.*

Secure the trim bezel with 8 screws on the inside of the enclosure.

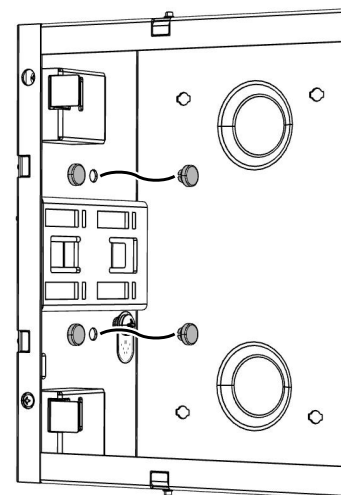
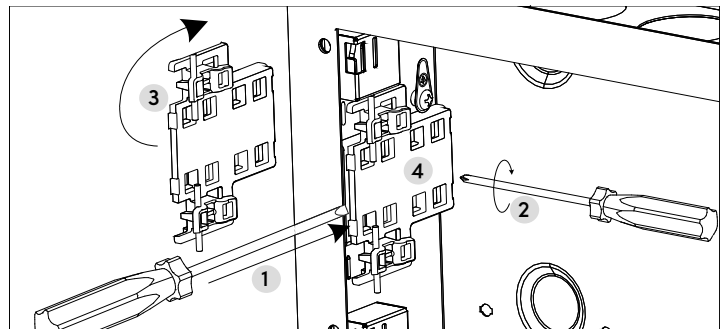

# Installing Equipment

**Warning:** Total equipment weight stored in this enclosure must not exceed 15 pounds.

The central support plate provides a variety of configuration options. For configuration examples and ideas, see the VersaBox Pro product page at [www.SnapOne.com](http://www.SnapOne.com).

## Knockouts & Modules

The knockouts at the top and bottom can be used for low voltage rings or for outlet boxes. Any outlet box used must be an old-work, residential-grade box with integrated work supports to allow for secure mounting.

Wherever you remove a cable/wire entry cover, insert a silicone grommet into the hole. When using these for wire access, slit each grommet down the middle in a "+" shape. When using these for conduit, cut the grommet to the exact size and shape of the conduit for a tight seal.

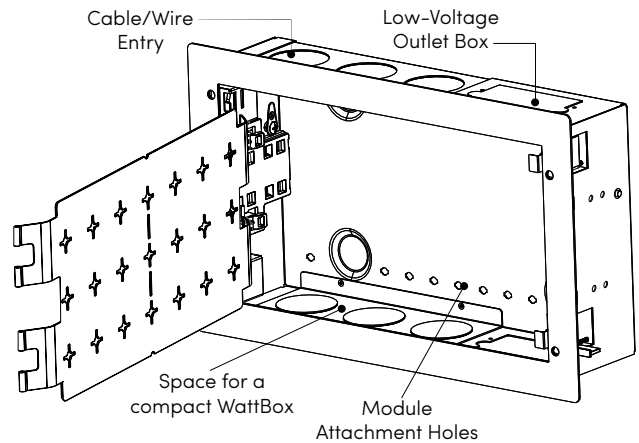

The back wall of the VersaBox Pro has holes and knockouts stamped into it on 6" centers for structured-can module installation. Use a 1/4" drill bit to widen the knockout stamps as needed.

## Adjusting the Platform Standoffs and Central Support Plate

Sections of the central support plate can be trimmed with tin snips for customized mounting options.

As noted under Stud Mounting with Lag Bolts (previous page), you can orient the standoff clips toward the front or rear of the VersaBox Pro.

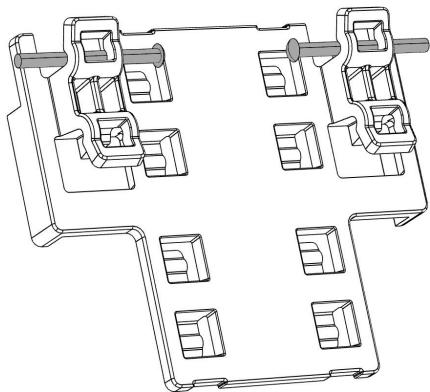

In addition, the standoffs have two clips to hold the central support plate: you can clip it toward the outside (left) or toward the inside (right).

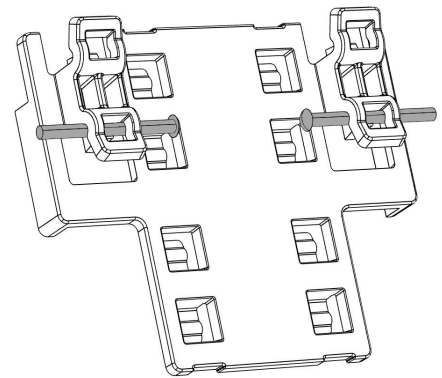

Finally, the central support plate can be inserted so that it curves toward the front of the enclosure, or recesses to the rear. Between the standoff orientation, the two clipping options, and the reversible support plate, this provides multiple depth options, up to being flush with the front of the enclosure.

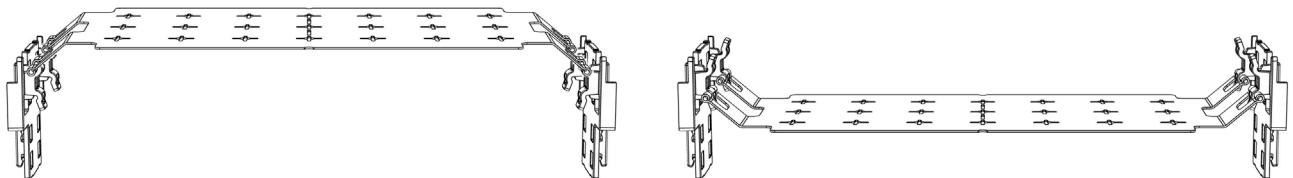

## Installing a Compact WattBox

Remove the bottom panel by unscrewing the four pre-installed screws. Insert the compact WattBox, and replace the four screws to secure it. For further installation information, see the WattBox product manual.

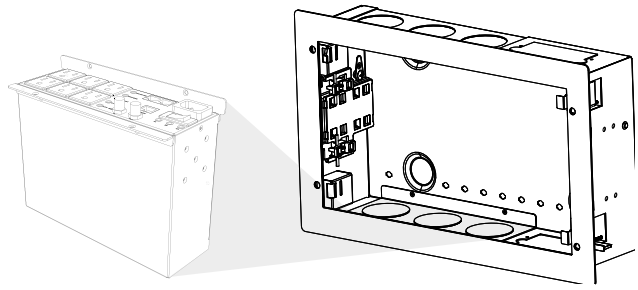

## Reattaching the Cover

To slide the cover on, seat the hooks on one side first, and push the other side in until it clicks.

## Dimensions

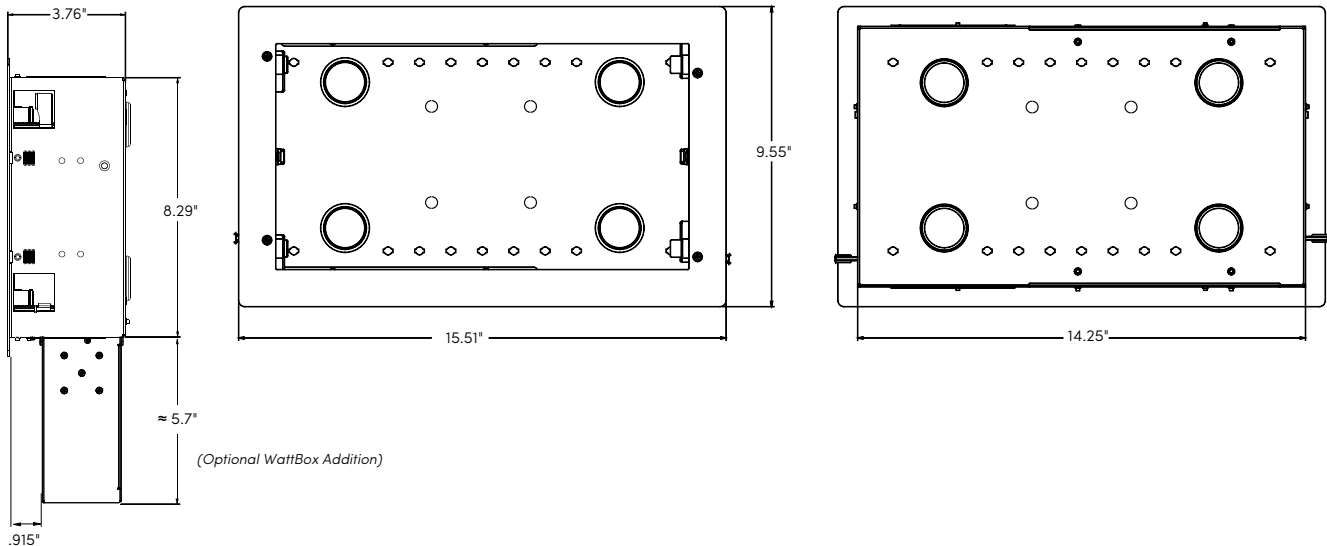

## Technical Support

For chat and telephone, visit <https://tech.control4.com/s/contactsupport> • Email: [TechSupport@SnapOne.com](mailto:TechSupport@SnapOne.com)  
Visit [tech.control4.com/technician](https://tech.control4.com/technician) for discussions, instructional videos, news, and more.

## Warranty and Legal Notices

Find details of the product's Limited Warranty and other resources such as regulatory notices and patent and safety information, at [snapone.com/legal](https://snapone.com/legal) or request a paper copy from Customer Service at 866.424.4489.

Copyright ©2021, Snap One, LLC. All rights reserved. Snap One and its respective logos are registered trademarks or trademarks of Snap One, LLC (formerly known as Wirepath Home Systems, LLC), in the United States and/or other countries. Strong, WattBox, and Wirepath are also registered trademarks or trademarks of Snap One, LLC. Other names and brands may be claimed as the property of their respective owners. Snap One makes no claim that the information contained herein covers all installation scenarios and contingencies, or product use risks. Information within this specification subject to change without notice.

211115-1541

Part # 200-SM-RBX-PRO-8-BLK-A

